

# CR SERIES TWIN ROTOR® COMBINES

CR6.80 | CR6.90 | CR7.90 | CR8.90 | CR9.90  
CR9.90 ELEVATION | CR10.90 ELEVATION



# ENTER A NEW HARVESTING DIMENSION

New Holland revolutionized the way farmers harvested over 40 years ago with the introduction of ground-breaking Twin Rotor® technology for combines. Today's latest generation of CR combines continues the pure rotary bloodline and offers best in-class grain and straw quality thanks to the gentle multi-pass action. The new, top-of-the-line CR10.90 Elevation is the most powerful and productive CR to date. The all-new Harvest Suite™ Ultra cab sets a new benchmark in terms of harvesting ergonomics and comfort. Innovative features such as the SmartTrax™, IntelliCruise™, IntelliSteer™ and Opti-Spread™ systems further enhance productivity, and together with Dynamic Feed Roll™ technology, continue to ensure that CR combines are one of the most advanced and productive harvesters in the world.



## OUTSTANDING CAPACITY

In 2008, and again in 2014, the CR combine broke the Guinness World Record for harvesting. The 653-hp(CV) FPT Industrial Cursor 16 Diesel Engine of the Year 2014, the huge engine that powers the CR10.90 Elevation, delivers efficient power. When combined with advanced harvesting technology, including IntelliSteer™ auto guidance, you can harvest around the clock. Twin Pitch rotor technology can improve capacity by up to 10% in high-moisture conditions. The optional Dynamic Feed Roll, with integrated dynamic stone protection, has improved already impressive capacity by up to 10%, and has enhanced crop flow into the rotors and reduced grain crackage. The CR keeps going as long as you do.

## SUPERIOR HARVEST QUALITY



Unsurpassed grain and straw quality is guaranteed, courtesy of gentle, yet highly efficient Twin Rotor® technology. Grain crackage is a thing of the past with an Industry-leading figure as low as 0.1%. Dynamic Feed Roll™ technology provides the most efficient on-the-go stone collection and the new serrated blades are even gentler on grain. Opti-Fan™ and self-leveling technology ensures the cleanest grain sample and you can choose between two types of rotors to match your individual harvesting needs.

## LOWER OPERATING COSTS



New CR combines benefit from industry-leading ECOBlue™ HI-eSCR technology to comply with the more-stringent Tier 4B emission regulations and it maintains the 10% fuel-saving efficiency you've come to expect of a CR combine. Add this to the long, 600-hour service intervals and the SmartTrax™ system for reduced soil compaction, and even more money stays in your pocket. Always.

## ABSOLUTE DRIVING PLEASURE



The all-new Harvest Suite™ Ultra cab has been designed to deliver ultimate harvesting comfort and ergonomics. The larger, 131 cubic foot cab with 68 square feet of glass, almost 7% more than previous models, means more freedom and visibility for more comfortable and more precise harvesting. At 73 decibels, it is still the quietest cab on the market. You can position the 10.4-inch, ultra-wide IntelliView™ IV color touchscreen anywhere on the ideal viewing arc to match your preference. If you're a night-time harvester, the new lighting package enables true, 24-hour productivity.

**Up to 410-bushel  
grain tank**

**Lighting package  
in HID or LED**

**Harvest Suite™  
Ultra cab**

**Four-chain  
feeding system**



**Dynamic  
Feed Roll™  
technology**

Up to 653-hp Cursor 16 engine with ECOBlue™ HI-eSCR Tier 4B technology



REAL CONDITIONS.  
UNBELIEVABLE PERFORMANCE.

On August 15, 2014, in Wragby UK, the CR10.90 Elevation obliterated the current GUINNESS WORLD RECORDS™ title for the most wheat harvested in eight hours. During the record it harvested 29,308 bushels of wheat in under eight hours, with peak capacity of 4,960 bushels/hour in real world conditions.

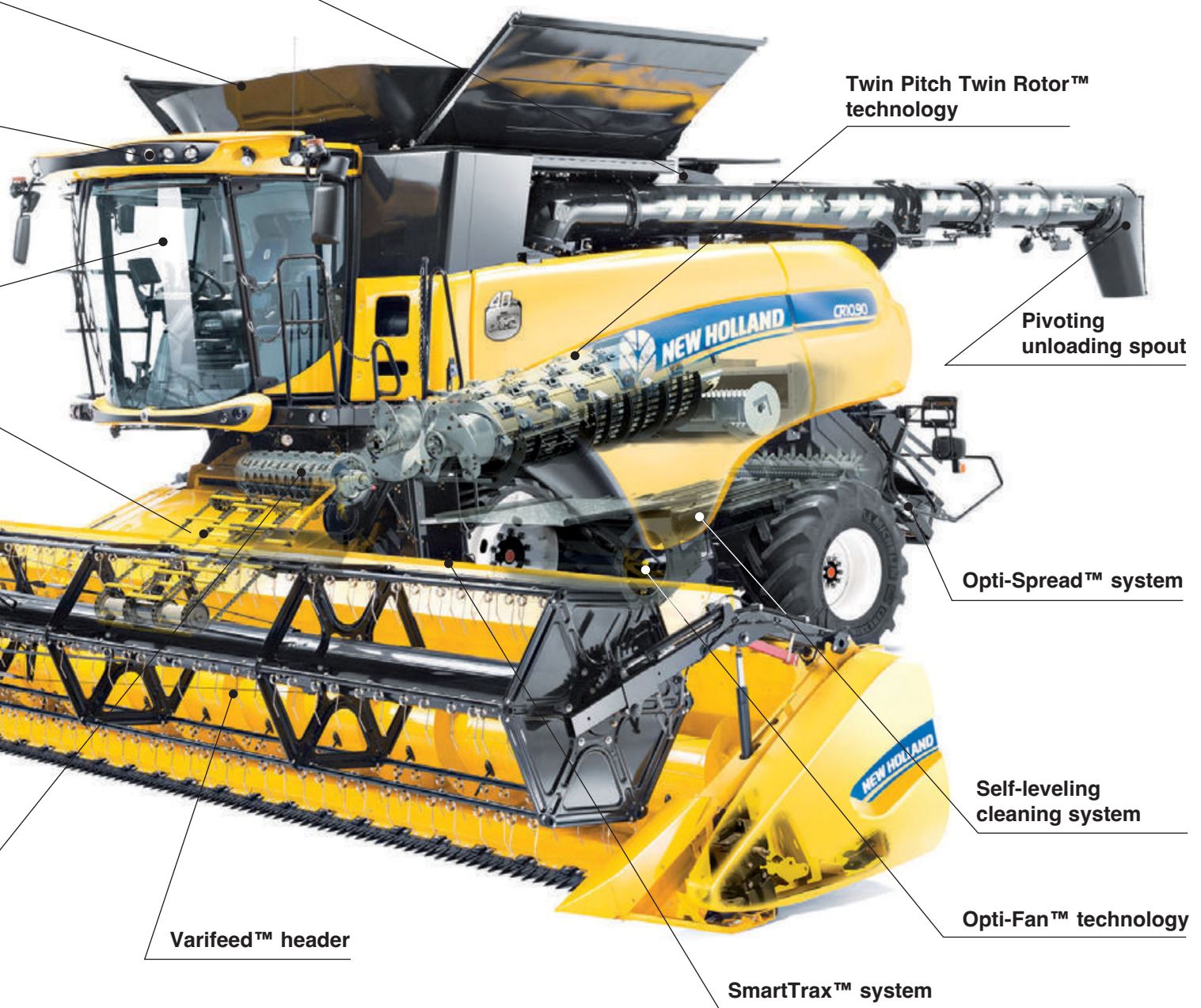

Twin Pitch Twin Rotor™ technology

Pivoting unloading spout

Opti-Spread™ system

Self-leveling cleaning system

Opti-Fan™ technology

Varifeed™ header

SmartTrax™ system

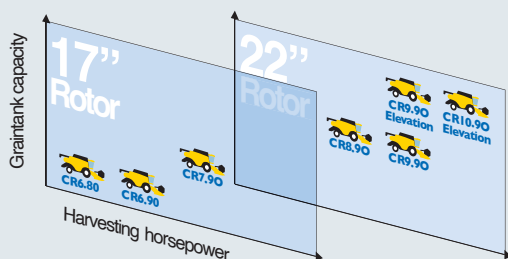

EXACTLY WHAT IT SAYS ON THE SHIELDING

The performance of a CR combine is immediately obvious. How? By the model number on the side! The first digit of the model number, whether a 6, 7, 8, 9 or 10 denotes the class of combine. The higher the number the more powerful the combine. The final two digits, either 80 or 90 indicate its position within the class. A higher number means a higher-capacity combine.

# THE HISTORY OF THE MODERN COMBINE BY NEW HOLLAND

Twin Rotor® technology can trace its roots back to Lexington, Nebraska, where, in 1975 the very first combine to boast this, then-revolutionary technology, rolled off the production line. Now, 40 years and nearly 40,000 combines later, after an unrelenting process of refinement and innovation, the tenth generation of Twin Rotor combines are carrying on this illustrious history. Built in Grand Island, Nebraska since 1986, and Zedelgem, Belgium since 2004, Twin Rotor combines continue to offer farmers unbeatable performance and quality.



1975



1979



1984



1993



1997



1999

**1975:** New Holland was a rotary pioneer, introducing Twin Rotor® technology with the TR70 (145-168 hp). The face of harvesting was changed forever.

**1979:** The second generation of Twin Rotor combines included the TR75, TR85 and TR95 with a power increase to 155-225 hp.

**1984:** A bigger cab, improved visibility and S<sup>3</sup> rotors characterized the TR76, TR86 and TR96 – the third-generation Twin Rotor machines welcomed by farmers.

**1993:** Almost a decade later, the TR87 and TR97 fourth-generation combines made their mark with more power for increased capacity.

**1997:** Simplified controls made harnessing even more power on the fifth-generation TR88 and TR98 combines more efficient and productive.

**1999:** Six generations down the line, higher grain-handling capacity and enhanced visibility were the hallmarks of the TR89 and TR99 model.

**2002:** A sleek seventh generation graced the world's fields with completely new styling, longer rotors, larger cab and the first self-leveling cleaning system on a rotary combine. The CR920, CR940, CR960 and CR970 models produced up to 370 hp.

**2004:** Twin Rotor combine production also begins in Zedelgem, Belgium, New Holland's Center of Harvesting Excellence.

**2005:** New Holland celebrates three decades of Twin Rotor® success with the introduction of the IntelliView™ II monitor for precision machine control.

**2007:** The CR9000 Series was the eighth generation and featured a whole host of productivity-boosting features including: up to 400-hp Tier 3 engines, 45-ft headers, 12-row cornheads and the IntelliView™ Plus II monitor for precision machine control and auto guidance functions.

**2008:** The CR9090 Elevation is officially the world's highest-capacity combine. It smashed the Guinness world harvesting record, officially harvesting 20,263 bushels of wheat in eight hours.

**2010:** New Holland celebrates its 35th anniversary for Twin Rotor combines. Production of the CR9060 for Latin America starts in Brazil.



2014

**2011:** The ninth generation of Twin Rotor combines is launched, featuring Tier 4A compliant ECOBlue™ SCR engines, improved capacity, as well as best-in-class grain and straw quality.

**2012:** CR Series combines are recognized as Machine of the Year 2012.

**2013:** The introduction of the Dynamic Feed Roll further improved in-field performance and grain quality.

**2014:** The CR10.90 smashes the GUINNESS WORLD RECORDS™ title for the most wheat harvested in eight hours. During the record it harvested 29,308 bushels of wheat in under eight hours in real world conditions.

**2015:** The 10th generation CR Series celebrates 40 years of harvesting excellence with the introduction of the benchmark Harvest Suite™ Ultra cab.

**The history of success continues!**

## LEADING FROM THE FRONT

New Holland knows that the harvesting process starts with the crop. How crop enters the machine determines the quality of your harvest, so New Holland offers the widest selection of heads in the business to harvest a vast array of crops. From small grain to grass and flower seeds, from rice to corn and beans, New Holland has the perfect match for high-capacity CR Series Twin Rotor® combines.

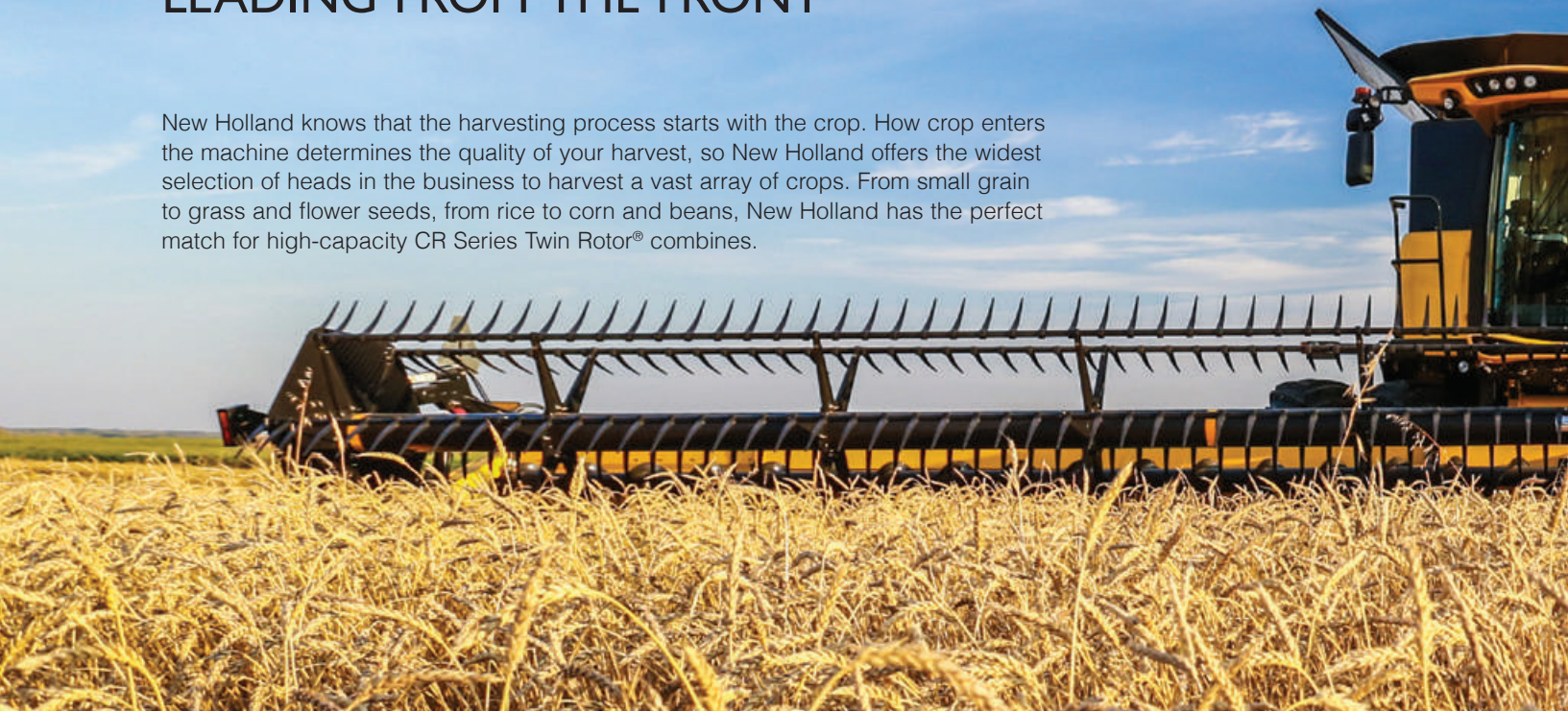

### 760CG VARIFEED™ GRAIN HEADS: ADAPT TO ALL TYPES OF CROP

For optimum harvest quality and a uniform cut in different crop heights, including tall, bushy, direct-cut canola, the Varifeed™ head is your perfect partner. You can adjust knife position a full 23 inches fore and aft from the cab for ideal feeding. The 26-inch diameter auger with deep flights provides fast, smooth feeding even in the heaviest crops. Full-width retracting fingers between each auger flight move crop down and under the auger. You can also adjust the reel electro-hydraulically in all directions from the cab for smooth, continuous feeding. These heads are available in 30-, 35- and 41-foot widths. The 41-foot Varifeed™ header is the ultimate choice for large fields with controlled traffic. The split auger manages large volumes of crop with ease, and dual-knife drives located at either end of the header maintain powerful cutting across the full cutterbar width and also deliver perfect weight distribution for uniform stubble height.



### 740CF DIRECT-CUT SUPERFLEX CUTTERBAR AUGER HEADS: FLEXIBILITY FOR PRECISE HARVESTING EFFICIENCY

If you harvest in undulating terrain, the 740CF Direct-Cut SuperFlex auger head is the natural choice. The SuperFlex knife bed flexes a full 4.5 inches to ensure a close cut and uniform stubble height in uneven fields, and the full-floating auger with deep flights provides fast, smooth feeding in the heaviest crops. When combined with 1,150 cuts per minute and the cab-based, hydraulic, fore-and-aft reel adjustment, precise feeding and processing are a given. You can even maintain a pre-set ratio between reel speed and ground speed, so that when ground speed changes, feeding remains consistent.



### 720CG HIGH-CAPACITY GRAIN HEADERS

In conventional farming situations, the traditional high-capacity grain headers are perfect. They feature heavy-duty construction with a hydraulic reel drive, perfect for the heaviest crops. The larger 24-inch-diameter auger and 1,150 cuts per minute improve capacity, forward speed and intake volumes.



#### FULLY INTEGRATED SIDE KNIVES

Optional 18-tooth vertical side knives are ideal to direct cut canola or other bushy crops. They slice through matted crops and are controlled through the IntelliView™ IV color touchscreen monitor. When not required, they can be stored on the header itself.



#### TERRAIN TRACER™

When harvesting on uneven ground, the Terrain Tracer™ system ensures you capture every grain of crop. The system automatically raises the head vertically and tilts the head laterally to follow the contours of your fields using one of three available modes:

- **Compensation Mode** is ideal for low-growing crops like peas and beans. This mode maintains a pre-established contact pressure
- **Stubble Height Mode** maintains a pre-set stubble height using sensors on the underside of the header
- **AutoFloat™ Mode** uses a combination of sensors to maintain a uniform stubble height, plus prevents bulldozing

Grain Auger Heads		CR6.80	CR6.90	CR7.90	CR8.90	CR9.90	CR9.90 Elevation	CR10.90 Elevation
720CG High-Capacity rigid cutterbar cutting width	ft	24, 30	24, 30	24, 30	24, 30	30	30	30
740CF direct-cut SuperFlex cutterbar cutting width	ft	20, 25, 30	20, 25, 30, 35	20, 25, 30, 35	25, 30, 35	30, 35	30, 35	30, 35
760CG Varifeed™ rigid cutterbar cutting width	ft	30	30, 35	30, 35	30, 35, 41	30, 35, 41	30, 35, 41	30, 35, 41

## HIGH-CAPACITY, SMOOTH-FEEDING HEADS

New Holland's broad line of combine heads continues with a choice of smooth-performing draper heads and windrow pickups. New Holland is dedicated to providing you with alternatives that maximize the capacity of your CR Series combine and bring your harvest home quickly and efficiently.



### 880CF SUPERFLEX CUTTERBAR DRAPER HEADS: ULTRA-CLOSE CUTTING AND MINIMUM LOSSES

New Holland draper heads are designed with industry-leading features. The award-winning New Holland SynchroKnife™ drive is a patented center knife-drive system that revolutionizes the way a combine header cutterbar is driven. It eliminates header vibrations, and reduces overall header loss, putting more crop in the grain tank. This system works on the same basis as the two opposing knife drives, but eliminates the vibrations they can cause by keeping the opposing knives perfectly synchronized. The drive also eliminates complex drivelines, reducing maintenance needs and saving power. Having the drive in the center of the head reduces the end shield width to minimize rundown of standing un-cut crop. The 880CF SuperFlex draper header provides ground-hugging flotation so farmers can harvest every bit of their valuable crop.



### 840CD RIGID DRAPER HEADS: ULTIMATE HARVESTING CAPACITY

The 840CD rigid draper head delivers outstanding performance in small grains and speciality crops such as rice. A six-bat New Holland-designed cam reel smoothly feeds crop to the cutterbar and draper belts, helping to reduce header loss.

Draper headers	CR6.80	CR6.90	CR7.90	CR8.90	CR9.90	CR9.90 Elevation	CR10.90 Elevation
880CF SuperFlex cutterbar draper cutting width (ft)	30	30, 35	30, 35, 40	30, 35, 40, 45	30, 35, 40, 45	30, 35, 40, 45	30, 35, 40, 45
840CD rigid cutterbar draper cutting width (ft)	25, 30	25, 30, 35	25, 30, 35, 40	25, 30, 35, 40, 45	30, 35, 40, 45	30, 35, 40, 45	30, 35, 40, 45





**790CP WINDROW PICKUP HEADS:  
A CLEAN FIELD IS A NEW HOLLAND FIELD**

Ideal for small grain and specialty crops, such as canola and grass seed, the 790CP features standard rear and optional front windguards to ensure even crop flow into the combine. The picking belt gently and efficiently transfers the crop onto the slatted transfer belt. This positive pickup action ensures continued harvesting productivity even in rained down or sprouting crops. A seed dam is an integrated part of the design—not a rubber add-on—and is located between the rear transfer belt roller and the floor, preventing losses to collect all the grain you pick.



Pick-up headers	CR6.80	CR6.90	CR7.90	CR8.90	CR9.90	CR9.90 Elevation	CR10.90 Elevation
790CP windrow pickup feeding width (ft)	12, 15	12, 15	12, 15	12, 15	12, 15	12, 15	12, 15

## A PERFECT MATCH FOR CORN

New Holland's corn head line-up is engineered to perfectly match CR Series combines. After enduring extensive field testing, the 980 Series corn heads—both rigid and folding versions—are proven to deliver improved harvesting productivity and reliability. Like combine. Like corn head.

### MODERN CORN HEADERS FOR MODERN CORN FARMING

New Holland's 980 Series corn heads have been redesigned to deliver superior gathering and feeding performance, so operators can work at increased ground speed and finish faster.

Dividers and islands on these corn heads are designed for optimal performance. The dividers guide corn stalks into the stalk rolls. The islands ensure that cobs fall into the auger and not onto the ground. The low-profile design of the dividers and islands reduces the chance of knocking down corn in terraces and during tight turns. It also exposes the front gathering chain sprocket, dramatically improving performance when picking downed corn. The end dividers not only improve accessibility and maintenance, they are also designed to minimize header losses in all crop conditions.

Dividers are made with roto-molded material for rugged durability. This material withstands harsh treatment and bounces back to its original shape. The plastic has grooves that direct loose corn kernels to the front of the combine. Replaceable wear strips are included in the high-wear areas of the points and islands.

A single, heavy-duty row unit (used on both chopping and non-chopping configurations) substantially improves the durability of the header, while the increased reliability of driveline components leads to less downtime and higher operating efficiency.

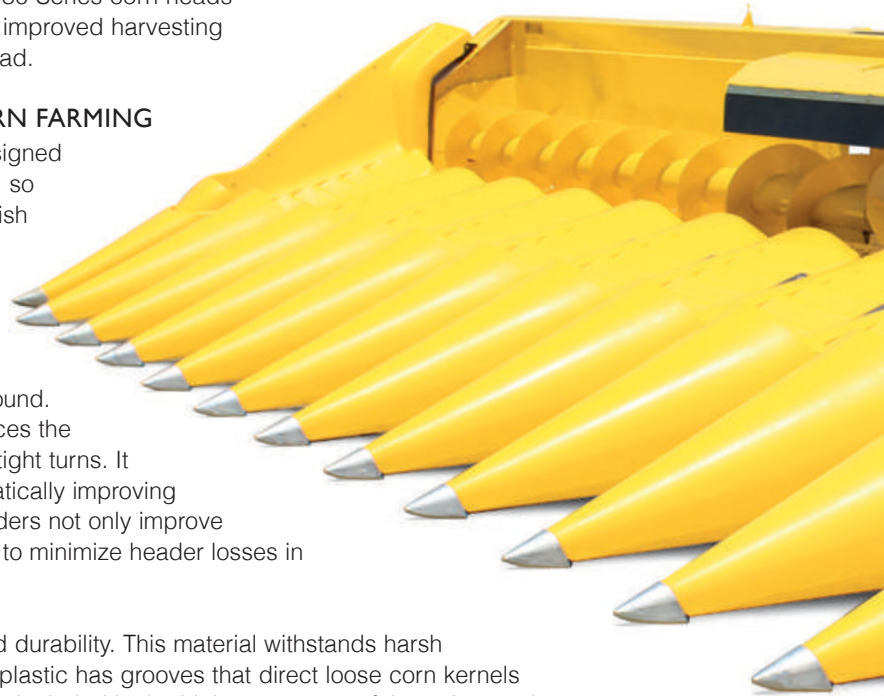

### EFFICIENT STALK CHOPPING

For fine chopping and superb spreading of mulched material, all 980 Series corn heads can be ordered with an optional heavy-duty stalk chopper. The stalk chopper chops the stalks as they are fed through the stalk rolls, and cuts any long stalks left in the rows. The knives are double edged for an increased working life. Each stalk chopper can be individually shut off to save power and increase part life when not in use. Customers agree: New Holland truly offers a best-in-class solution.



### DEPENDABLE OPERATION

Regardless of size, New Holland corn heads are designed for top harvesting performance in all crop conditions. The stalk rolls feature four knives that aggressively pull down stalks of any size. Operators can adjust deck plates electronically from the cab to adapt to changing stalk and cob size. Optional rotary dividers further enhance the already smooth crop intake in lodged or downed corn.

Corn heads	CR6.80	CR6.90	CR7.90	CR8.90	CR9.90	CR9.90 Elevation	CR10.90 Elevation
980CR corn head, 30" row spacing rows	6, 8	6, 8	6, 8, 12	8, 12, 16	8, 12, 16	8, 12, 16	8, 12, 16
36" row spacing rows	8	8	8	8	8	8	8
36" row spacing rows	8	8	8	8	8	8	8
980CF folding corn head, 30" rows rows	–	–	–	8, 12	8, 12	8, 12	8, 12



### STALK STOMPER TIRE PROTECTION

An optional Stalk Stomper kit is now available for fixed or folding corn headers to reduce tire or track wear when harvesting corn. Mounted on the header frame, the Stalk Stompers flatten the stubble in front of the wheels, greatly reducing the likelihood of punctures or uneven tire or track wear.



### CORNROWER™ FOR EFFICIENT BALING OF STOVER

The New Holland Cornrower fits perfectly behind 8- and 12-row 980 CR Series models chopping corn heads, to ensure that one uniform and dense windrow of corn stover is produced to assist with efficient baling. You pick, chop and windrow in one swift motion, reducing the number of passes through the field to save time and fuel and reduce field compaction—all without affecting combine performance. The minimal maintenance Cornrower attachment provides precise control of the amount of residue left in the field while increasing baler intake capacity and keeping dirt out of the bale. It's perfect for second-generation bioethanol producers. Attachment is easy with no need for modification of the head.



### FOLDING OR RIGID: THE CHOICE IS YOURS

Rigid heads are available in 6-, 8-, 12- and 16-row configurations so you can choose just the right size for your fields and customers. The folding frame of the 8 and 12-row 980CF models allows you to fold the head from inside the combine, drive to the next field, unfold the head from the comfort of the cab, then continue the harvest. Folded width of the 12-row model is 16.2 feet. One operator alone can do it, with no trailer, no tow vehicle, and no need to get out of the seat; that's New Holland Smart!

## A NEW BENCHMARK FOR HARVESTING COMFORT

The Harvest Suite™ Ultra cab offers you a home away from home during long harvesting days and nights. This cab is completely new from the floor up and is the result of extensive customer consultation. It's larger with 68 ft<sup>2</sup> of glass—7% more than previous models. More space and more glass mean more comfortable and precise harvesting. You can enjoy all that space in the peace and quiet of the near silent 73dB(A) cab.

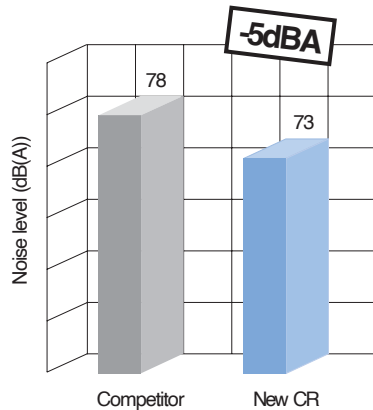

### ARE YOU SITTING COMFORTABLY?

Choose from three seating options:

1. The standard wide cloth-trimmed seat provides exceptional features and ensures all operators will stay comfortable throughout the longest harvesting day.
2. The optional deluxe cloth-trimmed seat with heating and active ventilation is perfect for the hottest days and the coldest nights, and features fore/aft isolation for even more comfort.
3. The top-of-the-line leather-trimmed seat features all the above and extended vertical travel and automatic weight adjustment that absorbs even the most severe bumps, offering the ultimate in operator comfort and style.

### 360 PANORAMIC VIEW

The Harvest Suite™ Ultra cab's wide curved window offers a perfect view. The floor slopes down into the front windscreen so that you will have an even clearer view of the edge of the header, and the side glass perfectly follows your headers trajectory for an uninterrupted view of the unloading auger. Standard wide-angle electric mirrors mean you can see in all directions, and can position them easily from the comfort of the cab. You can manage up to three optional viewing cameras through each IntelliView™ IV monitor, and one can be pre-wired for reversing. They are the eyes in the back of your head when unloading, reversing or checking the grain tank level.



### BRIGHT LIGHTS FOR DARK NIGHTS

The CR's lighting package has raised the lighting bar. The spread of light has been precision engineered for maximum visibility of the entire header and the field ahead and behind. Precision unloading in the dead of night. You'll never lose a single grain thanks to a specific unloading auger light. Additional rear lamps enable operators to monitor residue and two lamps located on the side panels illuminate the rear axle to prevent running down standing crop and to assist when maneuvering. You even have the choice between HID and LED packages. You can also exit your combine in complete safety courtesy of the entrance light, which remains on for 30 seconds after you've switched the combine off.

### STAY REFRESHED ON THE HOTTEST DAYS

During long hot harvesting days, the optional integrated fridge under the instructor seat means a refreshing drink is only an arm's length away. And, it can be removed easily for easy replenishment. The Automatic Temperature Control (ATC) system comes as standard equipment and automatically adjusts fan speed to guarantee accurate temperature to within one degree. The Harvest Suite Ultra cab is definitely the coolest place to be.

## EFFORTLESSLY MAXIMIZE YOUR PERFORMANCE

Intelligent and intuitive automation saves time and enhances harvesting performance. The CommandGrip™ multi-function handle is your right-hand harvesting man. You control all key machine and header parameters, including header height, reel position and unloading engagement. The right-hand console contains less frequently used functions, which are laid out in an ergonomic and logical manner. You monitor machine functions at a glance courtesy of the color IntelliView™ IV display.



Forced-based movement enables the operator to change speed and direction

- Reel speed and header reverser direction control
- Emergency Stop (Header and Unloading)
- Reel position, Varifeed™ knife or fold-up corn header plus shift button
- Unloading auger position or unloading auger pivoting spout position plus shift button  
Unloading auger engagement
- IntelliSteer™, IntelliCruise™ engagement and Cruise Control
- Automatic header height activation
- Two-speed header lift, lowering system and header lateral movement



Shift button and ground speed unlock (behind)

- Header and feeder reverse activation
- Opti-Spread™ control
- Engine speed
- Automatic header height modes
- Header width correction
- Automatic Crop Settings switch
- IntelliCruise™ activation
- Powered rear wheels engagement
- Chopping / Swathing selection
- Electronic park brake
- Electronic gear selection





### A PLACE FOR EVERYTHING

You now have space to store everything you need. A large compartment behind the operator is perfect for stowing away essential documents.



### WIDE-SCREEN HARVESTING

The ultra-wide 10.4-inch IntelliView™ IV color touchscreen display is mounted on rollers which allow it to move along an ideal viewing arc so you can position it just where you want. This intuitive display allows you to monitor all combine functions and change views by simply touching the screen. A second screen can be installed on request and is perfect for IntelliSteer™ auto guidance tasks or for displaying camera views.



- Header and feeder engagement
- Threshing engagement
- Header vertical side knives left and right engagement
- Road / Field mode
- Reel speed synchronization
- Rotor speed control
- IntelliSteer™ guidance activation
- Concave position
- Grass seed unload
- Open / close grain tank cover
- Fold / unfold unloading auger
- Cleaning fan speed
- Upper sieve opening
- Lower sieve opening

## ENHANCED PROTECTION FOR IMPROVED EFFICIENCY



The CR's feeding system has been significantly upgraded to enhance its already highly efficient operation. The feeder features four chains with connecting slats on the CR8.90, CR9.90, CR9.90 Elevation and CR10.90 Elevation models for improved crop flow and even smoother feeding into the Twin Rotors®. The CR Series benefits from an impressive header lift capacity for ultimate productivity when working with the very largest headers, and you can choose between the Advanced Stone Protection system or the optional, Dynamic Feed Roll™ system which both ensure the threshing mechanism is always fully protected.







### ADVANCED STONE PROTECTION SYSTEM

The unique Automatic Stone Protection System (ASP) uses a detection sensor located under the closed lower drum of the straw feeder. When a stone is detected, the full width, pivoting ejection door automatically opens and the stone is ejected. The ASP system requires minimal operator input and ensures an unobstructed flow of the crop from the feeder to the rotors. This maximizes grain and straw quality, increases capacity and, of course, protects internal feeding elements for extended machine life.

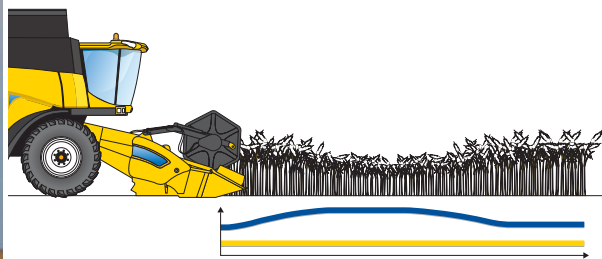

### INTELLICRUISE FOR INCREASED PRODUCTIVITY

The IntelliCruise™ automatic crop feeding system automatically matches the forward speed to crop load. A sensor on the straw elevator driveline continually monitors the demand placed on the header, so in areas of lighter crop, forward speed automatically increases to guarantee the combine works at full capacity through areas of differing yield.



### MAKING BLOCKAGES A THING OF THE PAST

New Holland's unique hydraulic reversing system instantly clears any header and feeder blockages. You can "rock" the header and feeder backward and forward to feed material into the combine and effectively unblock the machine for minimum downtime and maximum harvesting uptime.

### DYNAMIC FEED ROLL™ SYSTEM OPTION

This on-the-go mechanical system delivers maximum feeding efficiency and stone detection effectiveness in extremely stony conditions. Stones are automatically directed by an 18-inch-diameter closed beater into a dedicated stone trap located between the feeder and rotors. There's no stopping, no hesitation, no interruption of the harvesting process. This non-stop harvesting system increases capacity by up to 15% when operating on the stoniest ground. The Dynamic Feed Roll™ system features serrated plates so that it is gentle on the crop to deliver higher-quality, more profitable grain and straw. Simply empty the stone trap module during routine maintenance.

## WORLD-CLASS GRAIN QUALITY

New Holland invented the Twin Rotor® concept over 40 years ago and has refined this evolving technology so that it delivers unmatched efficiency, capacity and grain quality. It's also a design that is extremely flexible, making it easy to match a CR Series combine to various crops, conditions, and operations. New Holland also knows that no two farms are alike, so two different types and sizes of rotor have been developed to match a farmer's specific needs. 17-inch diameter rotors are used on CR6.80, CR6.90, CR7.90 models, while the CR8.90, CR9.90, CR9.90 Elevation and CR10.90 Elevation models are equipped with the heavy-duty, high-capacity 22-inch rotors.

### MORE CENTRIFUGAL FORCE

Twin Rotors generate 36% to 40% more centrifugal force than any other rotary design, moving the grain quickly for faster separation and maximum throughput. This faster separation virtually eliminates grain damage and loss.

### GENTLE THRESHING, HIGHER QUALITY

A high level of grain-on-grain rubbing action releases grain quickly and gently—before it comes in contact with metal threshing components. This ensures gentle threshing with minimal damage; the Twin Rotor system delivers outstanding grain quality.

### ENHANCED PRODUCTIVITY WITH DYNAMIC FEED ROLL™

The addition of the optional Dynamic Feed Roll™ system which is located in front of the rotors, simultaneously speeds up the crop, for smoother, streamlined feeding, and automatically directs stones into a dedicated trap. This option available on all models except the CR6.80, improves feeder performance by up to 10%-15% thanks to greater throughput.

### ● EVERYTHING IN GOOD TIME

You can precisely position the optional rotor covers with adjustable vanes to either accelerate or slow crop flow, adjusting the time provided to thresh and separate the grain.

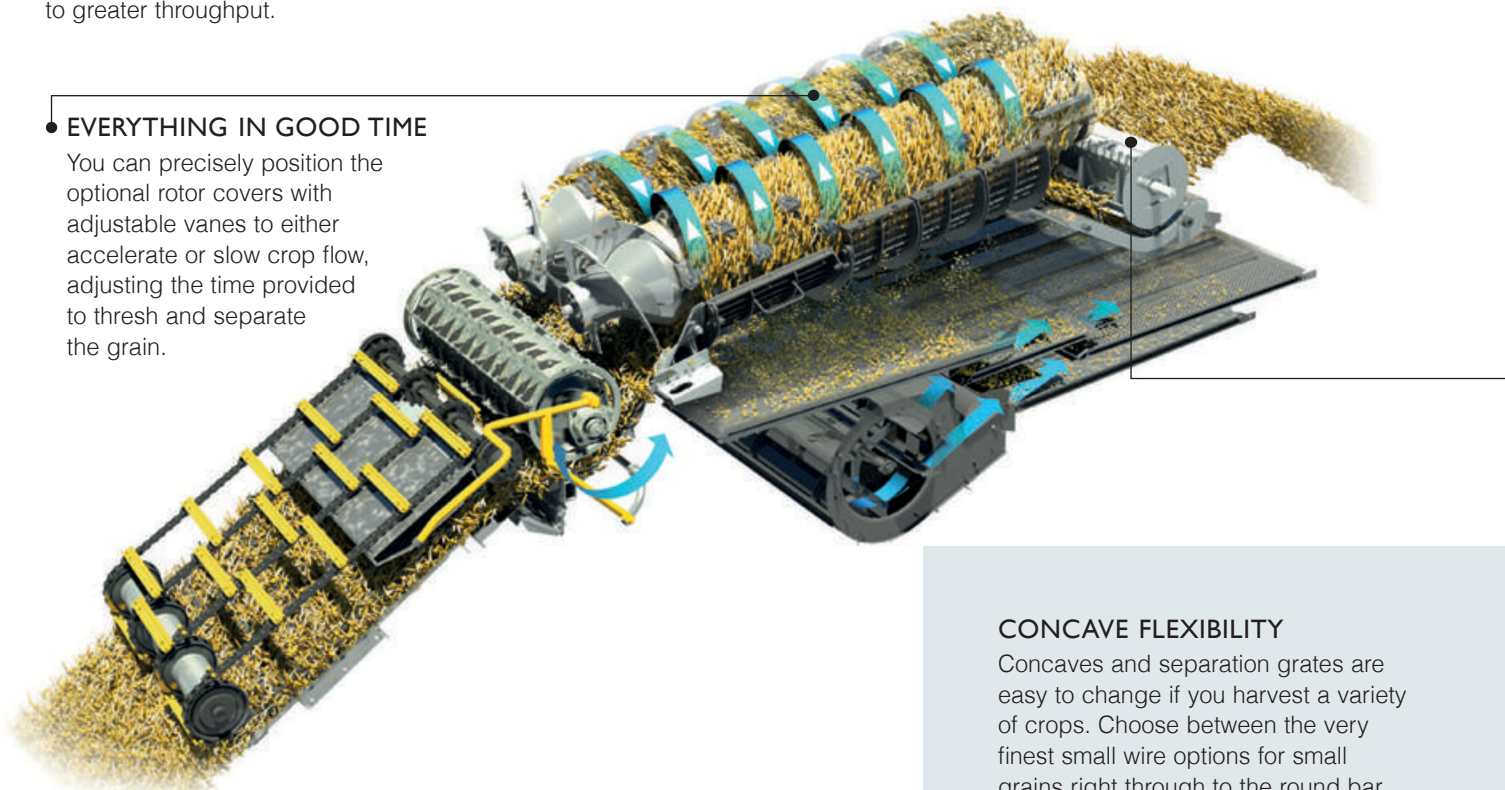
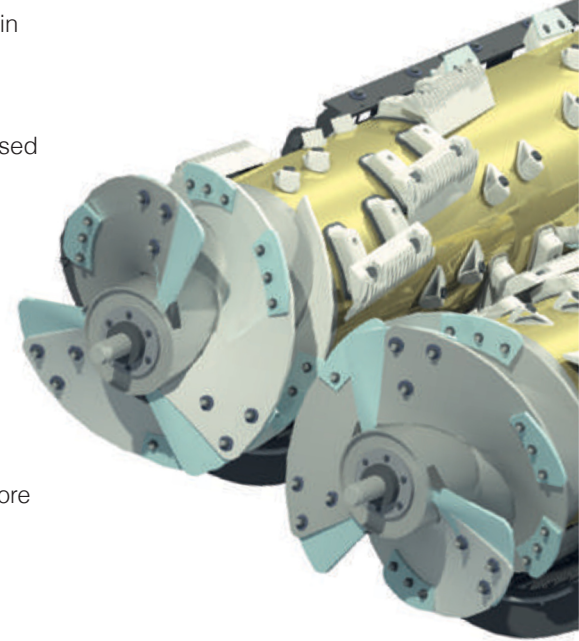

### CONCAVE FLEXIBILITY

Concaves and separation grates are easy to change if you harvest a variety of crops. Choose between the very finest small wire options for small grains right through to the round bar concaves and grates for corn and soybeans.

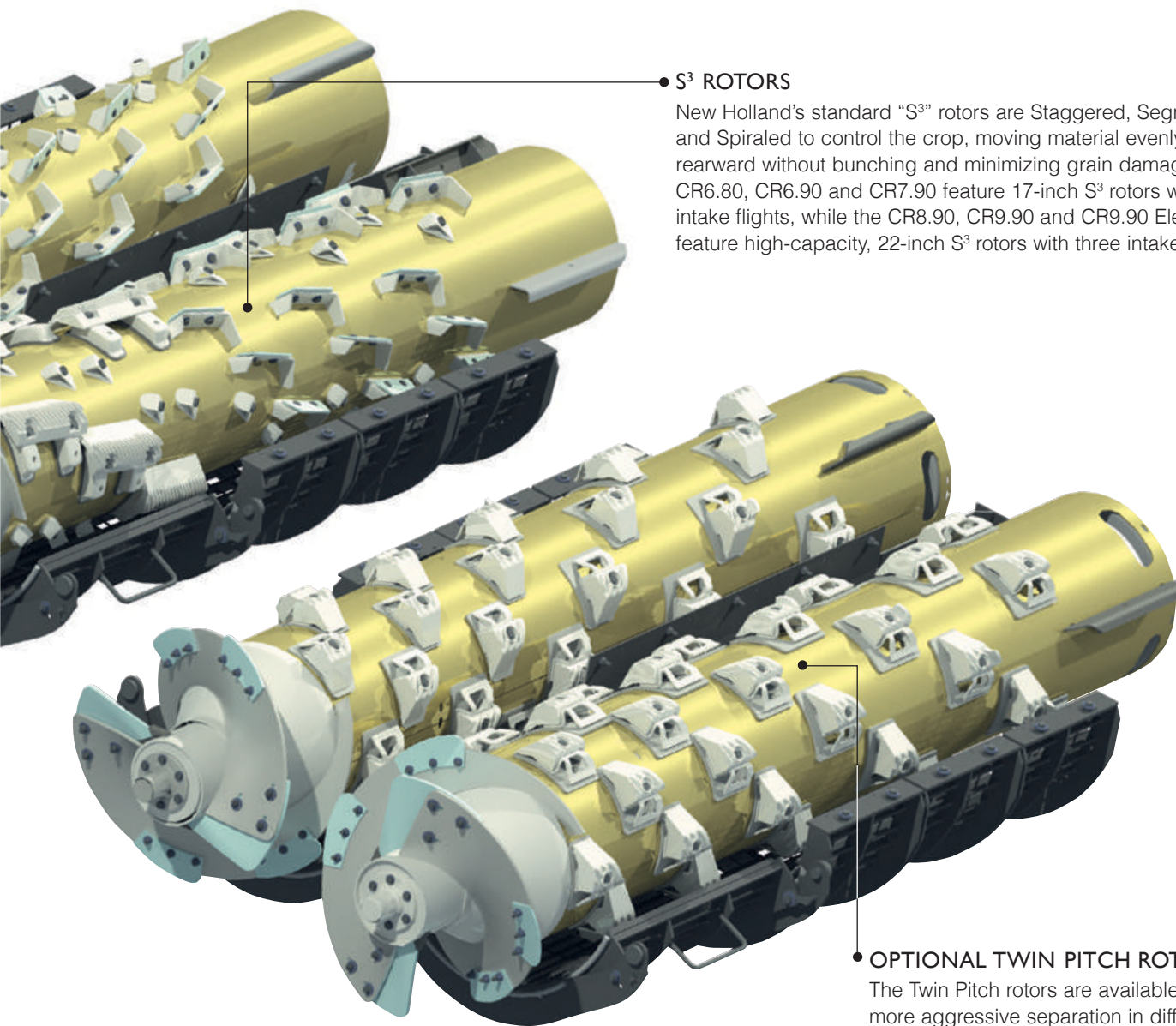

#### ● S<sup>3</sup> ROTORS

New Holland's standard "S<sup>3</sup>" rotors are Staggered, Segmented and Spiraled to control the crop, moving material evenly rearward without bunching and minimizing grain damage. The CR6.80, CR6.90 and CR7.90 feature 17-inch S<sup>3</sup> rotors with two intake flights, while the CR8.90, CR9.90 and CR9.90 Elevation feature high-capacity, 22-inch S<sup>3</sup> rotors with three intake flights.

#### ● OPTIONAL TWIN PITCH ROTORS

The Twin Pitch rotors are available for more aggressive separation in difficult harvesting conditions where they can lead to a 10% increase in capacity. They are standard for harvesting rice and standard on the CR10.90 Elevation model. They are available as an option on all other models with the exception of the CR6.80.

#### ● STRAW PROCESSING

When the straw reaches the end of the rotors, the 15.7-inch-diameter straw flow discharge beater moves and accelerates the straw to the rear of the combine.



#### THE PERFECT MATCH WHATEVER YOUR CROP

A full range of accessories allows you to customize your CR Series combines for your specific needs, including rasp bars, agitation pins, separating wedges, as well as concaves and separator grates.



## THE CLEANEST GRAIN SAMPLE

Best-in-class grain quality and the industry's cleanest grain sample. It must be the CR. Don't just take our word for it. In comparative grain sample tests, Twin Rotor® technology beat the competition hands down. The result: a minuscule 0.1% broken grain. How? Thanks to the unique Twin Rotor® concept which ensures in-line crop flow for the gentlest grain handling. Grain quality is further enhanced by award-winning features including the Aggressive Shake, Opti-Clean™ and Opti-Fan™ self-leveling cleaning shoe systems.

### EFFICIENCY FROM FRONT TO BACK

While the cleaning systems on other combines use augers, which actually serve to mix grain and chaff together, the unique New Holland grain pan sets up for efficiency right from the start. Since the large grain pan has no dividers, grain can spread out, stratify and separate easily. When the grain falls from the grain pan, the pre-cleaning sieve improves cleaning efficiency by immediately separating up to 20% of the stratified grain. A long sieve stroke and steep throwing angle keep more material airborne for even greater cleaning efficiency.

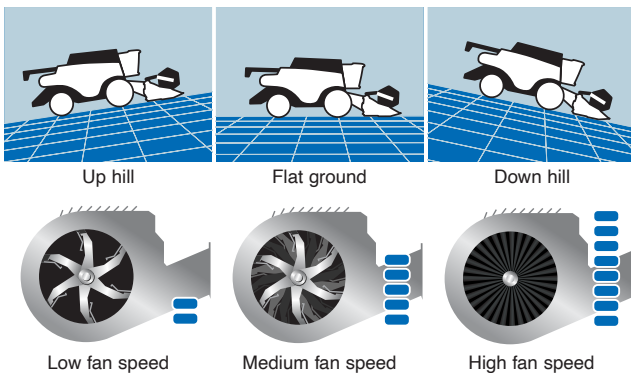

### GRAVITY DEFYING OPTI-FAN™ TECHNOLOGY

The Opti-Fan™ system compensates for the gravitational effects on crop material during harvesting. Select the desired fan speed on flat ground, and the system automatically adjusts it when going up or downhill to maintain cleaning performance. When travelling on upward slopes, the fan slows down to prevent sieve losses, and when tackling downhill gradients, fan speed increases to prevent thick material build ups on the sieves. This efficient system requires no extra work from the operator and provides a better grain sample together with reduced losses.

## THE CLEANEST GRAIN FOR THE HIGHEST REWARDS

With a total area under wind control of 10,075 square inches on the CR8.90, CR9.90, CR9.90 Elevation and CR10.90 Elevation, and 8,370 square inches on the CR6.80, CR6.90 and CR7.90, the CR Series cleaning system efficiently handles huge grain volumes. Both the Aggressive Shake shoe and the Opti-Clean™ system optimize the stroke and throwing angles of each of the main components in the cleaning system for higher throughput.

## AGGRESSIVE SHAKE FOR A BETTER QUALITY GRAIN SAMPLE

The aggressive shake system significantly enhances cleaning and throughput. This advanced system improves the transition between the cleaning shoe and the grain elevator and can manage high volumes of grain with ease. Throughput of up to 5,500 bushels per hour is effectively cleaned and processed and a 10% performance increase in high-yielding corn is possible. Select from two sieve positions—a throw angle of 26° for small grain and 36° for corn crops, with a shake angle that can be tailored to suit your individual crop.

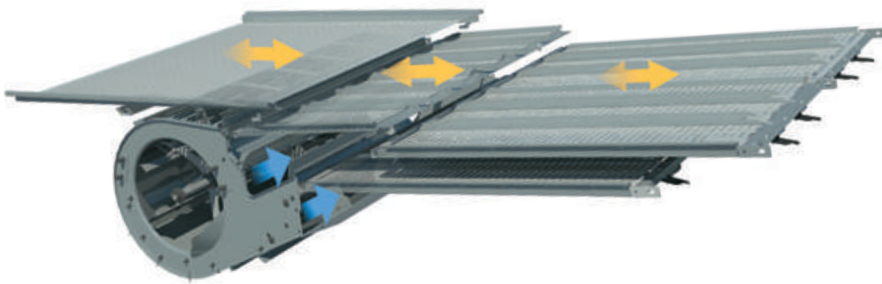

## PRECISION AIR FLOW

The unique CR Series fan design generates the largest air volume at a constant pressure. The fan has two dedicated openings to direct powerful airstreams to the pre-sieve and the top and bottom sieves for optimum cleaning performance.



## NEUTRALIZE SIDE SLOPES OF UP TO 17%

The self-leveling cleaning system is incredibly efficient on flat ground, and maintains this efficiency on slopes up to 17% and also prevents grain banking on headland turns to reduce grain losses. The entire cleaning system—the grain pan, cleaning fan and sieves—remains level while the lower main frame follows the ground contours. CR Series combines operate at full capacity on hillsides, corners and terraces.

## ADJUST YOUR SIEVES FROM YOUR SEAT

In changing crop conditions, you can adjust the sieves from the comfort of the cab. Open the sieve in heavier crops or reduce the sieve opening in lighter crops to prevent losses and improve efficiency.

## THE CR REMEMBERS YOUR CROPS

To reduce set-up time between crops or when working in varying crop conditions, CR Series combines “remember” up to 50 crop-specific settings for you with push-button Automatic Crop Settings (ACS). Select from pre-installed settings, or program two harvest parameters for each crop, including reel speed and position, rotor speed and concave setting, sieve opening and cleaning fan speed. Just recall these on the IntelliView™ IV monitor when required.



## CR9.90 ELEVATION AND CR10.90 ELEVATION THE OPTI-CLEAN™ SYSTEM

For the highest cleaning capacity in small grain crops such as canola, wheat and barley, the Opti-Clean™ system features a grain pan, pre and top sieves that operate independently to optimize the cascade for greater capacity. The longer sieve stroke and steep throwing angle keep more material airborne, for even higher cleaning efficiency. The opposing motion of the grain pan and bottom sieve to the pre-sieve and the top sieve reduces overall machine vibrations and increases operator comfort.

# HIGH-VOLUME GRAIN MANAGEMENT

## A SUPER-SIZE GRAIN TANK FOR SUPER-SIZED PERFORMANCE

Larger grain tank sizes perfectly match the CR's high capacity, for less frequent unloading and increased productivity. The unloading auger has been lengthened to match the performance of the new generation of CR combines and the widest matching headers.

## LONGER, STRONGER AND MORE ACCURATE

The new extra-long unloading spout has been completely redesigned for perfect compatibility with today's largest headers. You can fold and unfold the optional folding auger from the comfort of the cab. Folding reduces overall length to facilitate road transport and storage. You control the new pivoting spout using the CommandGrip™ multi-function handle to precisely direct the crop for even more uniform trailer filling. The 4.0-bushels-per-second unloading speed on the CR8.90, CR9.90, CR9.90 Elevation and CR10.90 Elevation means you'll empty the 410-bushel grain tank in under 2 minutes. Choose New Holland for less time unloading and more time harvesting.



Grain tank		CR6.80	CR6.90	CR7.90	CR8.90	CR9.90	CR9.90 Elevation	CR10.90 Elevation
Folding covers capacity	(bu)	326	326	326	410	410	410	410
Manually Folding Extensions, capacity standard/optional	(bu)	315	315	315/350	410	410	410	410
Unloading speed	(bu/sec)	3.7	3.7	3.7	4.0	4.0	4.0	4.0



## KEEP AN EYE ON YOUR GRAIN

While the CR Series sets a new industry standard for grain quality, the huge 36- x 22-inch viewing window makes it easy to keep an eye on your grain just the same. Simply glance over your shoulder to keep an eye on grain tank level, or refer to the IntelliView™ IV monitor. If you want to take things a step further, a grain sample flap on the outer operator platform allows you to take a physical sample.

## ROBUST OPTION FOR ABRASIVE CROPS

For prolonged operation in abrasive crops such as rice, the CR can be specified with the 'abrasive option.' The rotor covers, grain elevator, bubble-up auger and unloading auger are manufactured in heavy-duty materials to withstand prolonged operation in such crops.



## HIGH-PERFORMANCE GRAIN TANK

The 410-bushel grain tank on the CR8.90, CR9.90, CR9.90 Elevation and CR10.90 Elevation can hold 16% more grain than its predecessor. How? The grain tank extensions fan out, allowing even more room for grain so you can go even longer between unloading, saving you money on grain carting. It means operators spend more time doing what they do best: harvesting. You can choose the optional grain tank covers that can be closed electronically from the comfort of the cab. The covers reduce grain losses when working on steep inclines and protect grain during overnight storage. The bubble-up auger evenly distributes grain in the tank to assure all available space is utilized.



## FLEXIBLE RESIDUE MANAGEMENT SUITS YOUR OPERATION

New Holland offers a comprehensive residue management system that you can tailor to your needs. Whether you want to chop or swath, whether you want to include the chaff in the swath or spread wide, New Holland provides systems that deliver. You can even change between chopping and swathing from the comfort of the cab. Simple, fast, typically New Holland.



### CHOP TO DROP IS AS EASY AS PRESSING A SWITCH

As an option on CR8.90, CR9.90, CR9.90 Elevation and CR10.90 Elevation models, you can make the switch between chopping and dropping using a switch on the right-hand console. It's simple and fast. No need for tools. No need to change components. No need to even get out of the cab.

### CHOP FINE, SPREAD WIDE.

New Holland straw choppers are the perfect match for CR Series combine performance, featuring four rows of knives with wind blades installed at the outer edges of the rotor for high spreading capacity. The high, 3500-rpm rotor speed ensures fine chopping and wide spreading of even the heaviest crops. New Holland has enhanced chopping performance even further with the addition of Dual Chop technology. By installing a dedicated rake beneath the chopper rotor, a superfine chop of all material is possible.





### OPTI-SPREAD™ STRAW MANAGEMENT SYSTEM

The powerful Opti-Spread™ system option, mounted behind the straw chopper, uses two spinning rotors and two adjustable deflectors to evenly distribute chopped straw across the full header width. It meets a wide range of spreading width requirements simply by opening and closing the deflectors. Adjusting the deflectors also controls evenness of spread and neutralizes the effects of side winds or sloping ground. The system includes automatic memory of deflector position to both right and left. You control the system using three convenient in-cab controls.

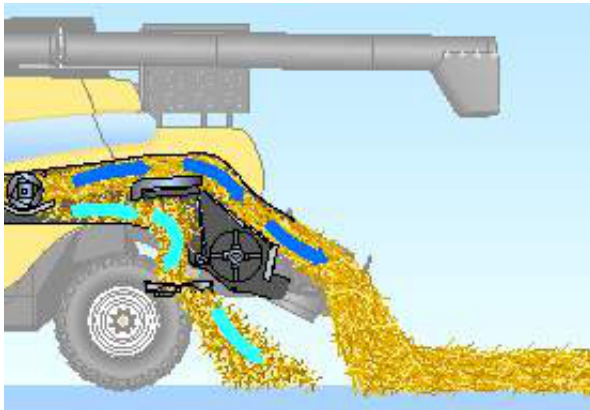

### STRAW IDEAL FOR BALING

CR Series combine straw is perfect for baling. Twin Rotor® technology offers perfect in-line crop flow, and eliminates the need for aggressive changes in speed and direction. As a result, the straw structure is maintained and breakages are minimal, even when working at the highest outputs. This makes the straw perfect for baling. The deluxe residue management system with PSD™ Positive Straw Discharge provides complete control of chaff and swath, easily changing from chopping to swathing. Use the twin-disc chaff spreader to spread chaff or direct it onto the ground, under the straw to be baled.

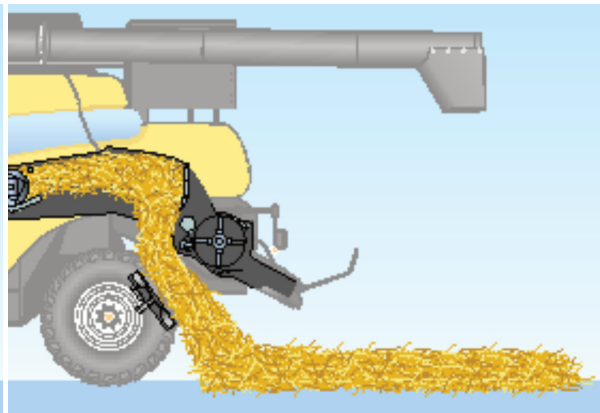
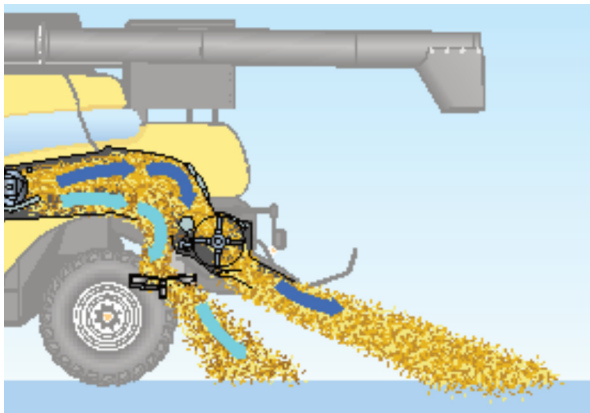

### TRADITIONAL STRAW CHOPPING AND SPREADING

For corn customers who are looking for traditional simplicity, the standard residue management system is an economical and robust solution that guarantees output.

# POWER AND RESPECT. FOR YOU. FOR YOUR FARM. FOR THE FUTURE.



*Sustainable Efficient Technology*

New Holland continues as the Clean Energy Leader, committed to making agriculture more efficient while respecting the environment, respecting your farm and your future.

## ECOBLUE™ HI-ESCR TECHNOLOGY FOR TIER 4B COMPLIANCE

The entire CR series, excluding the CR9.90 Elevation\*, is equipped with ECOBlue™ HI-eSCR engines which are Tier 4B compliant. They maintain the impressive 10% fuel savings and transient response established by Tier 4A CR combines. The flagship CR10.90 Elevation is powered by the Diesel Engine of the Year 2014 which features common rail technology for precision fueling and outstanding responsive performance.

\* CR9.90 Elevation is equipped with Tier 4A ECOBlue™ SCR technology

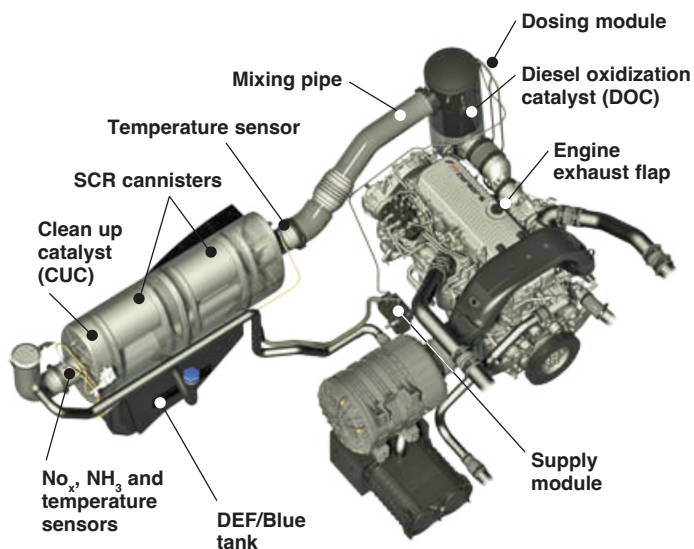

## DOUBLE UP FOR EFFICIENCY

The CR10.90 Elevation features a dual rotary dust screen which delivers optimal cooling performance for the highest power engine available on a combine today.

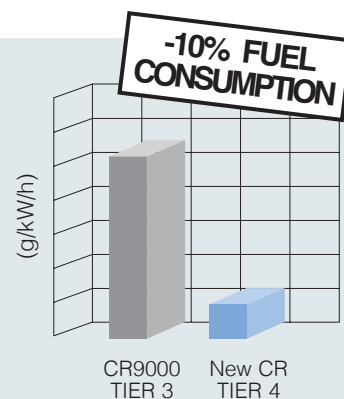
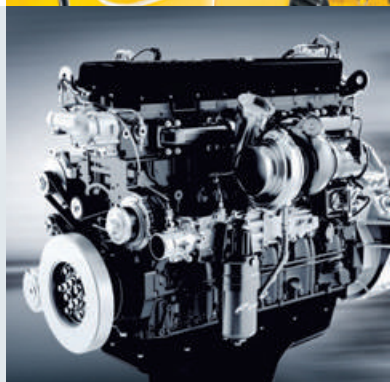

## THE ECOBLUE ADVANTAGE: BREATHABILITY

The proven ECOBlue™ technology uses AdBlue/DEF to transform the harmful nitrogen oxides contained in the exhaust gas into harmless water and nitrogen. This after-treatment system is separate from the engine which means the engine only breathes clean, fresh air. What does this mean? Clean running power units that offer improved performance and enhanced fuel economy.

## MORE MONEY IN YOUR POCKET

CR engines not only help to save the environment, they help to save you a nice chunk of change, too—up to 10% savings in fuel! During road transport, engines can run at a low 1600 rpm, further reducing fuel consumption. Moreover, a 25-mph transport speed, which is available across the entire range, saves fuel and cuts transport time so you can increase productivity during harvesting windows.

Model	CR6.80	CR6.90	CR7.90	CR8.90	CR9.90	CR9.90 Elevation	CR10.90 Elevation
Engine*	FPT Cursor 9	FPT Cursor 9	FPT Cursor 9	FPT Cursor 11	FPT Cursor 13	FPT Cursor 13	FPT Cursor 16
Compliant with engine emissions regulations	Tier 4B	Tier 4B	Tier 4B	Tier 4B	Tier 4B	Tier 4A	Tier 4B
Capacity (L)	8.7	8.7	8.7	11.1	12.9	12.9	15.9
ECOBBlue™ HI-eSCR system (Selective Catalytic Reduction)	X	X	X	X	X	ECOBBlue™ SCR	X
Injection system	Common Rail	Common Rail	Common Rail	Common Rail	Common Rail	Unit injectors	Common Rail
Gross engine power @ 2100 rpm- ISO TR14396 - ECE R120 hp (CV)	333	360	408	469	530	530	598
Maximum engine power @ 2000 rpm- ISO TR14396 - ECE R120 hp (CV)	374	401	449	517	571	571	653

\* Developed by FPT Industrial



#### VAST TIRE OFFERING

Select from a wide range of traction and steering tires to suit your individual needs from the narrowest IF 800/70 R38 to negotiate narrow gates, up to the largest 900/65 R38 tires with Increased Flexion (IF) Technology which can reduce compaction by up to 35%. A full range of dual traction tire options are also available to further reduce compaction.

#### POWER SAVING DRIVELINES

Proven, direct drivelines and the four-speed hydrostatic transmission give you the reliability you appreciate. Simple, efficient positortorque variators mean more power for harvesting compared to heavy power-sapping CVT alternatives used by competitive-brand combines.

#### SUPER TIGHT TURNING

The compact CR Series design and impressive 50° steering angle give it a turning circle of under 46 feet. This means tighter headland turns for improved straw quality, and less time turning and more time harvesting.

## SMARTTRAX™ REDUCE COMPACTION. SUPERIOR COMFORT.

Order a CR Series combine factory-equipped with SmartTrax™ rubber tracks, and you not only get superior traction in damp and muddy conditions, you also get decreased soil compaction to enhance soil fertility. SmartTrax rubber tracks offer 60% less soil compaction compared to 520/85 R42 duals. Yet you get a turning radius that's comparable to a 900/60 R32 single-wheeled machine. With +/- 10-degree oscillation, SmartTrax move easily over levees, swales and ditches to keep you moving in uneven terrain.

### POSITIVE, EFFICIENT DRIVE

The positive lugs on the inner side of the tracks maintain physical contact with the drive wheel for the ultimate in efficient power transmission.



### AUTOMATIC TRACK ADJUSTMENT

Tracks are tensioned automatically when you raise the head to full height or swing the unloading auger out or in—how's that for convenience? The continuous heavy-duty tensioning system maintains correct track tension for ideal traction. And, this tensioning system is completely separate from the drive wheel for ultimate simplicity and reliability. Another time-saving feature - no daily grease zerks to maintain.

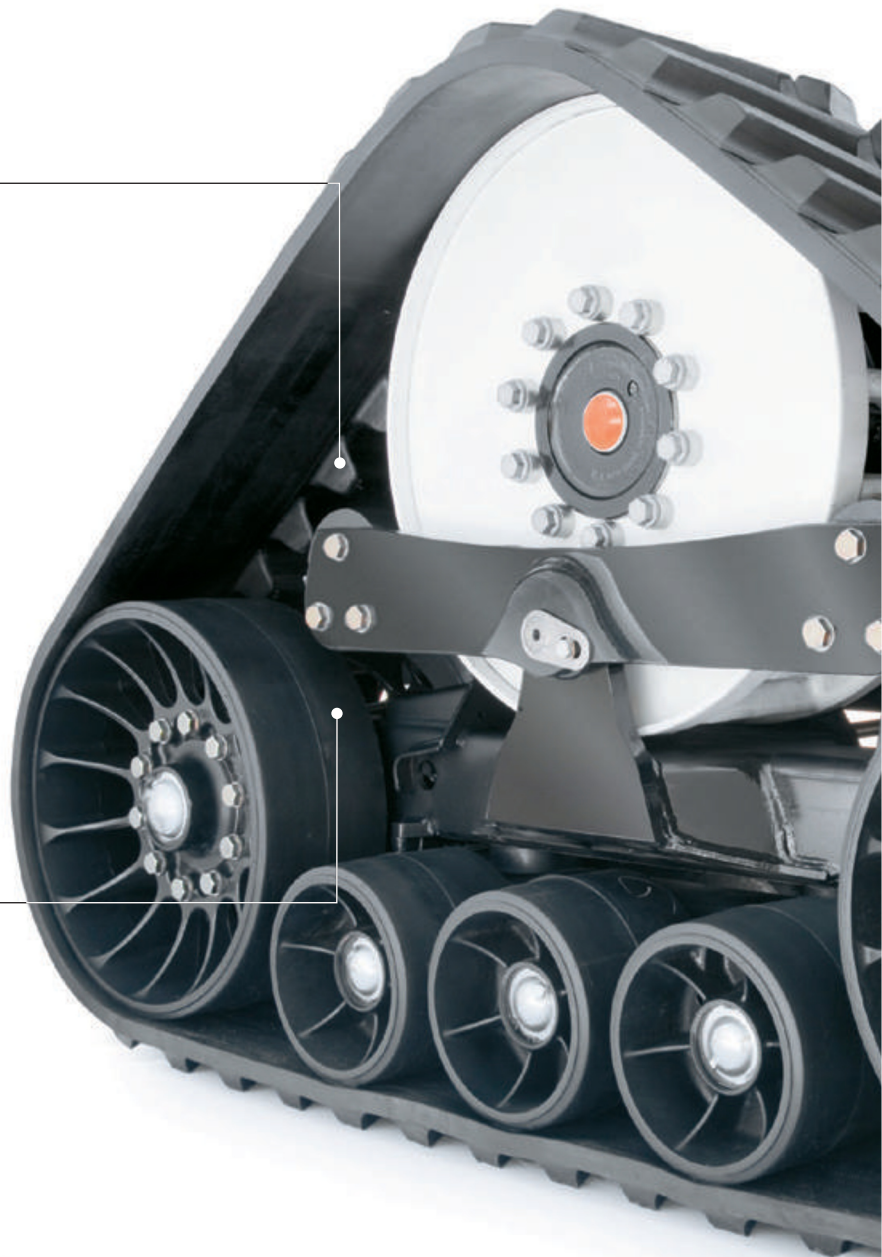

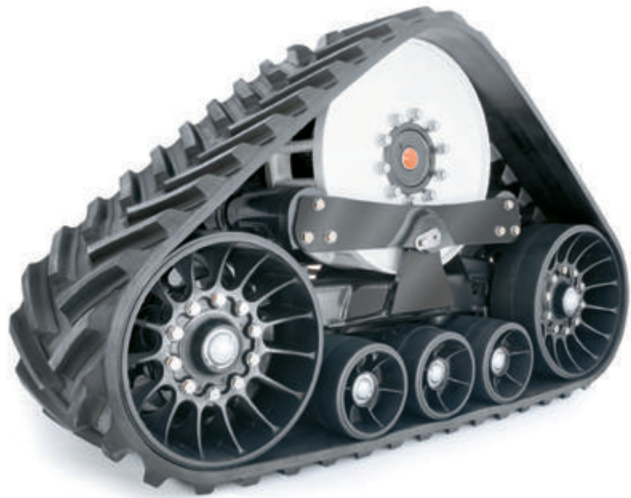

### GLIDE OVER THE FIELD IN ABSOLUTE COMFORT

Why complicate matters? Simplicity is always the best policy. The SmartTrax option features an integrated rubber block suspension system which significantly reduces vibration when compared to a traditional fixed track system. It offers tried and tested, reliable comfort during even the longest harvesting days and in road transport situations. Ride quality is further improved by the three central independent rollers which move in conjunction with the terrain to cushion the operator from even the harshest shocks.



### TRACTION WITHOUT QUESTION

The SmartTrax triangular design, together with the rubber cleats on the outer belt, ensure a positive contact with the soil and unsurpassed traction when working on the steepest slopes or in the wettest or dustiest conditions.

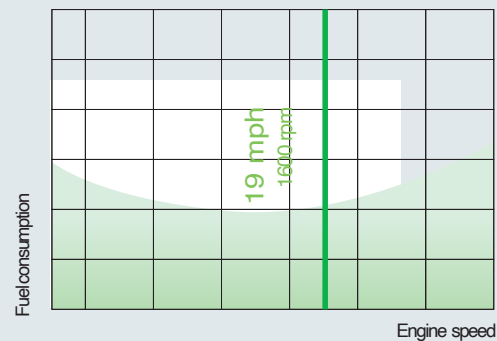
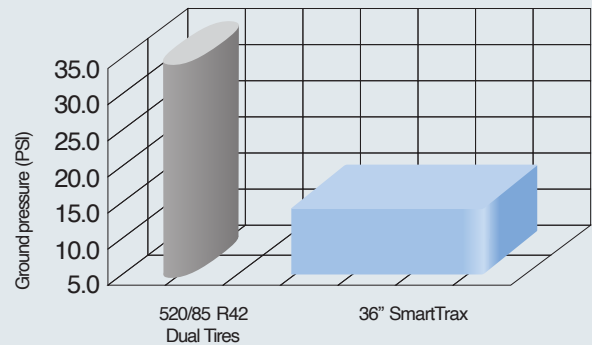

### HIGH ROAD SPEED, LOW OPERATING COST

Low 1600 engine rpm combined with a high road speed of 19 mph minimizes the time lost travelling between fields. Fuel economy is further enhanced by the super-low rolling resistance, which offers significant savings over competitor solutions.

## GUIDANCE SYSTEMS TO MATCH YOUR NEEDS

Choose from a full range of New Holland Precision Land Management (PLM) solutions for your CR combine.

### FULLY INTEGRATED INTELLISTEER™ AUTO GUIDANCE

You can order your CR combine with fully integrated IntelliSteer™ auto guidance direct from the factory to start saving money from your first run. The IntelliSteer system is an integral part of the combine's steering system and uses DGPS or RTK to help ensure parallel pass-to-pass accuracy as precise as +/- 1 inch. IntelliSteer benefits include less operator fatigue and full, more effective use of header cutting width, which leads to higher capacity every day.



#### INTELLIVIEW IV: VISIBLE INTELLIGENCE

Use the standard IntelliView™ IV monitor to set up the optional IntelliSteer™ auto guidance system. You can program a variety of guidance paths, from straight A-B runs to complex adaptive curves. You can also personalize your settings and transfer information from your combine, direct to your precision farming software package.



#### INTEGRATED CONTROL SYSTEMS

The IntelliSteer™ System uses built-in T3 terrain-compensated correction signals to keep the Navigation Controller II informed of the combine's orientation (roll, pitch, yaw). An integrated control valve in the hydraulic system converts the signals from the Navigation Controller II into movements of the steering system.



### CORN GUIDANCE

Corn heads are available with automatic row guidance to keep your CR Series combine perfectly on the row. Two sensors continuously monitor the position of the crop entering the head, and automatically guide the combine to ensure true perpendicular entry—even in poor visibility or at high speeds. The system can also be linked to a GPS positioning system, which can distinguish between cut and uncut rows, for night harvesting and advanced harvesting activities such as skip row functionality.



### LEVELS OF ACCURACY AND REPEATABILITY

New Holland offers a wide range of accuracy options. This enables you to select the right IntelliSteer® system to match your needs and budget. When using RTK correction with IntelliSteer it is possible to deliver year on year repeatability.

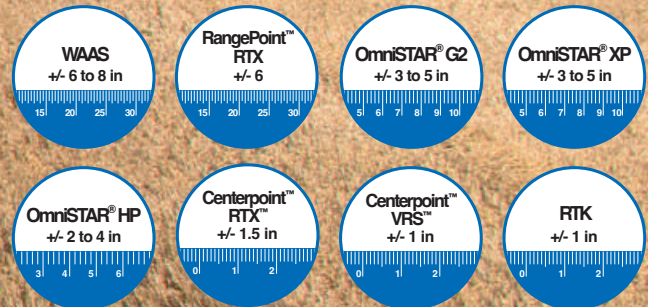

### NH 372 RECEIVER

The New Holland 372 antenna receives both DGPS and GLONASS signals and is fully compatible with EGNOS, OmniSTAR, or RTK correction. For RTK applications, a slim-profile radio is mounted underneath the receiver. The antenna is positioned on the top of the grain tank to improve signal reception and enhance operation.



### RTK BASE STATION

For the highest degree of accuracy, use an RTK base station that broadcasts a correction signal that allows you to achieve sub-inch pass-to-pass accuracy.

# INTEGRATED YIELD AND MOISTURE SENSING

## INTEGRATED MONITORING FOR INCREASED YIELD AND CROP QUALITY

CR combines are engineered with precision farming features right at their heart. Yield information is continually updated and displayed on the IntelliView™ IV monitor. This data can be stored, downloaded and analyzed with precision farming software to establish accurate yields maps. These can be used to fine tune inputs to maximize yields and minimize input costs.



### REAL-TIME MOISTURE SENSING

New Holland's moisture sensor measures grain moisture in real time. It takes samples every 30 seconds and sends the data to the IntelliView™ IV monitor. The operator is kept continually informed and can adapt machine parameters accordingly.



### BEST-IN-CLASS YIELD SENSOR FOR ACCURATE YIELD MAPPING

New Holland's exclusive, patented, high-accuracy yield sensor is generally recognized as best in class. Its design neutralizes the rubbing effect of grain. Whatever the kind, the variety or the moisture content of the kernel, the sensor generates an extremely accurate yield measurement. And, calibration is performed just once a season\*, and the system then automatically adapts to changing crops and conditions. You get hands-off operation for ultimate harvesting simplicity.

\*Requires one-load calibration per crop type with significant yield variation.



# NEW HOLLAND PLM® SOFTWARE

## PLM® CONNECT: MANAGE YOUR MACHINES FROM THE COMFORT OF YOUR OFFICE

PLM® Connect enables you to connect to your combine and other equipment from the comfort of your office or on-the-go with a mobile device. You can stay in touch with your machines at all times, and you can even send and receive real-time information that saves time and enhances productivity. The entry-level PLM® Connect Essential package offers the most frequently used features or upgrade to the PLM® Connect Professional package for full machine monitoring and control.

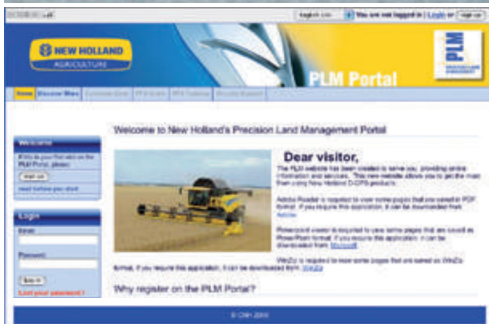
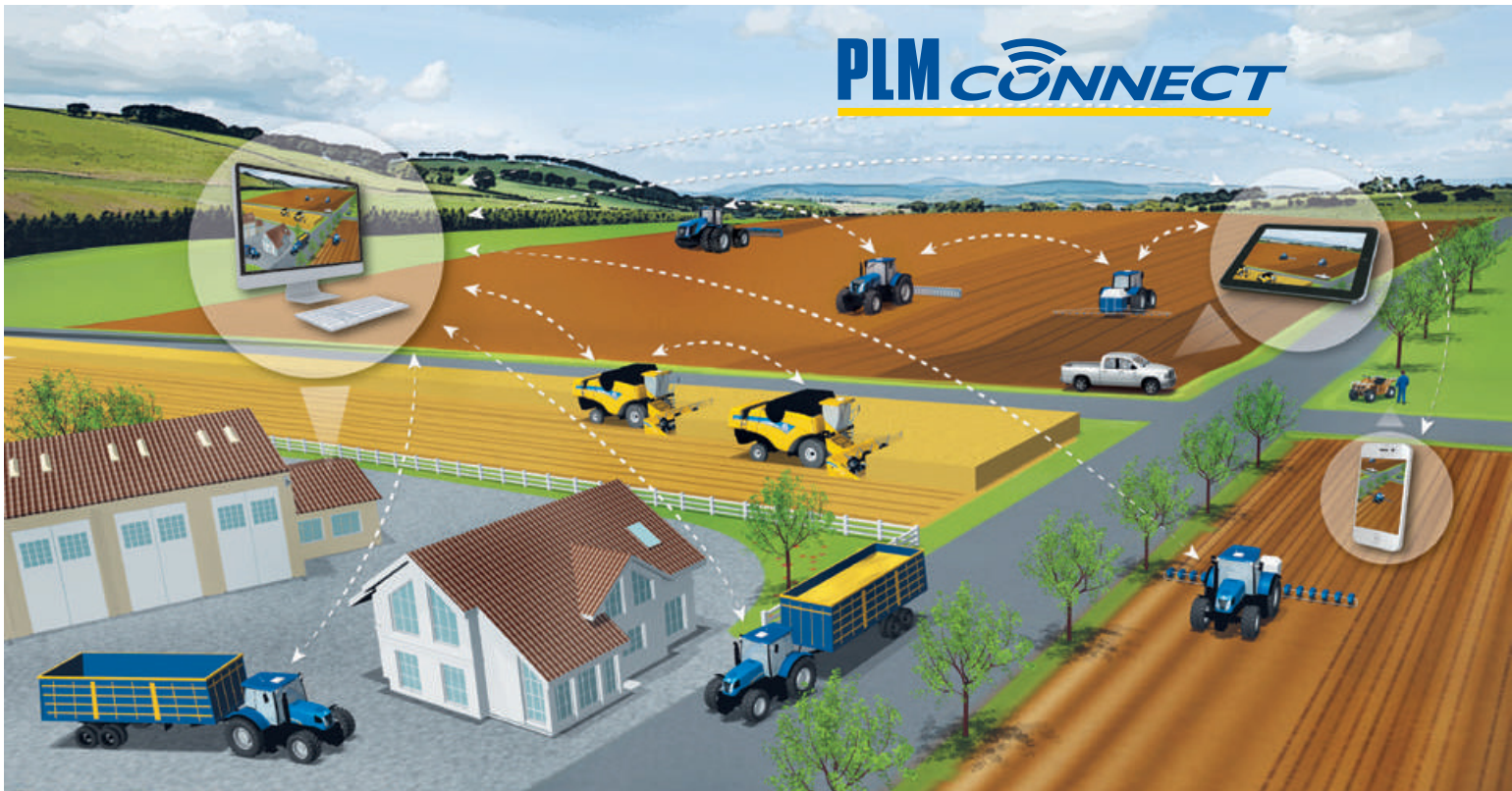

## PROFESSIONAL CUSTOMER SUPPORT: PLM PORTAL

New Holland created the PLM portal to support New Holland customers who have purchased Precision Farming and Auto Guidance products. Available to all New Holland customers, visit [www.newhollandplm.com](http://www.newhollandplm.com) today. Once you have signed in, you have unlimited access to the most advanced information on all New Holland Precision Farming and Auto Guidance systems. There is also a section dedicated to training videos and customer support information.

New Holland offers a variety of precision farming packages which allow you to tailor your inputs to reduce your costs and increase your yields. This information is recorded in real time by your machine while working, and it is simply and efficiently transferred for analysis by the computer package from the IntelliView™ IV monitor via the complementary 4GB USB stick, which is large enough to record data from over 1500 – 1750 acres.

## 360° : CR

CR combines are designed to spend more time working and less time on maintenance. After all, we all know how precious time in the field is during short harvesting seasons. The Grease Plus variator lubrication function guarantees even lubrication of all moving parts, and resets speed to original settings. The Clean Plus system simplifies cleaning between crops. It automatically increases the speed and opens all functional components, then resets everything back to their prior settings. All service points are easy to access, and super-long service intervals mean CR combines will spend more time in their natural environment: the field!



Check engine and hydraulic oil at a glance, without the need to open complicated panels.

The CR10.90 Elevation has a dual rotary dust screen to maintain ultimate efficiency. You get easy access to the radiator thanks to the wide opening door, making maintenance a breeze. Manage the clean-out function through the Clean Plus button on the IntelliView™ IV monitor.

Self-supporting, fully opening shielding guarantees wide access to all drives and service points.



The engine oil and air filter is easy to access from the engine platform.

The fuel and 42-gallon AdBlue®/DEF tanks are conveniently located next to each other to facilitate simultaneous filling.

Easy ground access to oil filters and drain points and centralized greasing banks mean more efficient maintenance.

Plastic rotor covers can be removed without tools to make seasonal checks more easy and simple.

### DEALER INSTALLED ACCESSORIES

A comprehensive range of approved accessories to optimize machine performance in all conditions can be supplied and fitted by your dealer.



The optional integrated water tank is ideal for washing hands after connecting the header.

# SPECIFICATIONS

MODEL		CR6.80	CR6.90	CR7.90	CR8.90	CR9.90	CR9.90 ELEVATION	CR10.90 ELEVATION
<b>Combine Class</b>		6	6	7	8	9	9	10
<b>Harvest Suite™ Ultra cab glass area</b>	ft. <sup>2</sup>	68	68	68	68	68	68	68
HID lighting pack		○	○	○	○	○	○	○
LED lighting pack/ far distance lights		○	○	○	○	○	○	○
Standard cloth trimmed seat with air-suspension								
Deluxe cloth trimmed heated air-suspension seat with Active Ventilation		○	○	○	○	○	○	○
Leather trimmed heated air-suspension seat with Active Ventilation		○	○	○	○	○	○	○
IntelliView™ MIV monitor with adjustable position								
2nd IntelliView™ MIV monitor		○	○	○	○	○	○	○
Viewing cameras		○	○	○	○	○	○	○
Automatic climate control and coolbox								
Integrated fridge under instructor seat		○	○	○	○	○	○	○
MP3 Bluetooth radio (hands free phone calls)		○	○	○	○	○	○	○
Optimum cabnoise level - ISO5131	(dB(A))	73	73	73	73	73	73	73
<b>Automatic Header Control Systems</b>								
Terrain Tracer™ system/ Autofloat™ system								
<b>Straw Elevator</b>								
Number of chains		3	3	3	4	4	4	4
ASP™ system (Advanced Stone Protection)								-
Dynamic feedroll system		-	○	○	○	○	○	
<b>Twin Rotor® Technology</b>								
S <sup>2</sup> rotors								-
Twin Pitch rotors		-	○	○	○	○	○	
Rotor diameter / length	in.	17 / 104	17 / 104	17 / 104	22 / 104	22 / 104	22 / 104	22 / 104
Adjustable rotor vanes		○	○	○	○	○	○	○
<b>Cleaning</b>								
Self-levelling cleaning shoe with Opti-Fan™								
Opti-Clean™ cleaning system		-	-	-	-	-		
Enhanced aggressive shake shoe cleaning system							-	-
Total sieve area under wind control	in. <sup>2</sup>	8,370	8,370	8,370	10,075	10,075	10,075	10,075
<b>Grain tank and Unloading</b>								
Grain tank manual folding extensions, standard/optional	bushels	315	315	315/350	410	410	410	410
Folding covers capacity	bushels	326	326	326	410	410	410	410
Unloading speed	bu/sec	3.7	3.7	3.7	4.0	4.0	4.0	4.0
Folding unloading tube		-	-	-	○	○	○	○
Pivoting unloading tube spout		-	-	-	○	○	○	○
<b>Residue Management</b>								
Integrated straw chopper								
Remote chop / drop selection		-	○	○	○	○	○	○
Opti-Spread™ residue management		-	-	-	○	○	○	○
<b>Engine* Compliant with Tier 4 Emissions Regulations</b>								
ECObLue™ Hi-eSCR system (Selective Catalytic Reduction)							-	
Gross engine power @ 2100 rpm	(CV) HP	333	360	408	469	530	530	598
Maximum engine power @ 2000 rpm	(CV) HP	374	401	449	517	571	571	653
<b>Fuel Tank</b>								
Diesel capacity / DEF capacity	gal.	200 / 42	200 / 42	200 / 42	340 / 42	340 / 42	340 / 42	340 / 42
<b>Transmission</b>								
Differential lock		○	○	○	○	○	○	○
Road transport speed	20 mph / 25 mph	/ -	/ ○	/ ○	/ ○	/ ○	/ ○	/ ○
Factory installed SmartTrax™ system		-	○	○	○	○	-	-
<b>New Holland Precision Land Management Systems</b>								
IntelliSteer™ ready automatic guidance system								
IntelliCruise™ system		○	○	○	○	○	○	○
<b>Weight</b> - Standard version less header	lbs.	38,779	38,779	40,600	42,236	42,635	44,240	45,898
Dimensions with traction wheels**		900 / 75 R32	900 / 75 R32	900 / 75 R32	900 / 75 R32	900 / 75 R32	900 / 75 R32	900 / 75 R32
Wheelbase	ft. (m)	12' 4" (3.76)	12' 4" (3.76)	12' 4" (3.76)	12' 4" (3.76)	12' 4" (3.76)	12' 4" (3.76)	12' 4" (3.76)
Maximum height - transport	ft. (m)	13' (3.96)	13' (3.96)	13' (3.96)	13' (3.96)	13' (3.96)	13' (3.96)	13' (3.96)
Maximum width	ft. (m)	13' (3.96)	13' (3.96)	13' (3.96)	13' (3.96)	13' (3.96)	13' (3.96)	13' (3.96)
Maximum width - transport	ft. (m)	10' 10" (3.3)	10' 10" (3.3)	10' 10" (3.3)	10' 10" (3.3)	10' 10" (3.3)	10' 10" (3.3)	10' 10" (3.3)

| Standard    ○ Optional    - Not available\*

Developed by FPT Industrial

\*\*Traction wheels other than those mentioned are also available

# VALUE, SERVICE AND SOLUTIONS

There's a certain way of thinking that comes from living on a farm. Farming takes equal parts brain and brawn. Not to mention thick skin, calloused hands and a fair share of know how. Seasoned farmers know it helps to have equipment that's built by farmers, sold by farmers and used by farmers.

**Support at every step.** When you place your confidence in New Holland agricultural equipment, you get the finest in local support. Your New Holland dealer understands the many challenges you face and stands behind you at every step with the equipment, parts, service and financial solutions to make your job easier. Look to New Holland for a complete selection of equipment, including a full line of tractors, hay & forage equipment, harvesting, crop production and material handling equipment.

**Quality parts and service.** Turn to your New Holland dealer after the sale for expert, factory-trained service and genuine New Holland-branded parts. Your dealer has the very latest service updates and training to ensure your equipment keeps working productively season after season.

**Financing solutions.** Your New Holland dealer can tell you about smart ways to turn your financial challenges into opportunities with a portfolio of innovative financial services available through CNH Industrial Capital, including customized financing, leasing, insurance and the purchasing convenience of a Commercial Revolving Account.

For reliable equipment, parts and service — or just honest advice on farming and finance — turn to New Holland and your trusted New Holland dealer. We know. We're farmers, too.



We are proud to support the FFA.

Learn more at [www.newholland.com/na](http://www.newholland.com/na)

Design, materials and/or specifications are subject to change without notice and without liability therefor. Specifications are applicable to units sold in Canada, the United States, its territories and possessions, and may vary outside these areas.

© 2015 CNH Industrial America LLC. All rights reserved. New Holland is a trademark registered in the United States and many other countries, owned by or licensed to CNH Industrial N.V., its subsidiaries or affiliates. Any trademarks referred to herein, in association with goods and/or services of companies, other than owned by or licensed to CNH Industrial N.V., its subsidiaries or affiliates, are the property of those respective companies.



Safety begins with a thorough understanding of the equipment. Always make sure you and your operators read the Operator's Manual before using the equipment. Pay close attention to all safety and operating decals and never operate machinery without all shields, protective devices and structures in place.

NH31CR68071 • 021515 • AC • PRINTED IN U.S.A.